



(Designed & Manufactured by **RC EXPLORER TEAM**)

Radon Brushless Speed Control System User Guidelines

1. Technical /Specifications:

Model:		<i>Radon- Pro</i>	<i>Radon-Sport</i>
Continuous current:		140A	95A
Burst Current (10sec):		720A	490A
Battery Input:	3.7V LiPo	2 ~3cells	2 cells
	1.2V NiMh/NiCd	4-6 cells	4-6 cells
BEC Output:		Linear 6V/3A	Linear 6V/3A
Weight (not include wiring & fan):		~46g	~46g
Dimension(L x W x H) mm (Include the fan assembly to the ESC)		~39.5x30x30	~39.5x30x30
Motor limit with 2cell x 3.7V Lipo. The motor timing is at 0 degree		4.5 Turn or over	5.5 Turn or over

2. Features:

- * Ultra-smooth, Precise Throttle and Braking Control
- * Compatible with Sensored/Sensorless Brushless Motors
- * Data Analysis Capability(RPM, Low voltage and ESC temperature)
- * HotWire PC Interface for Advanced Programming and Updating
- * Easily Programming through the Program card
- * Built-in one touch On/Off switch with LED
- * Built-in Low voltage cut-off, Overheat protection and signal loss protection

3. Component Included:

- Speed control, Power capacitor, BEC wire, 25x25mm Fan, sensor wire, USB wire and USB device

Noted: Program card is not included in the package



4. Connection Diagram:

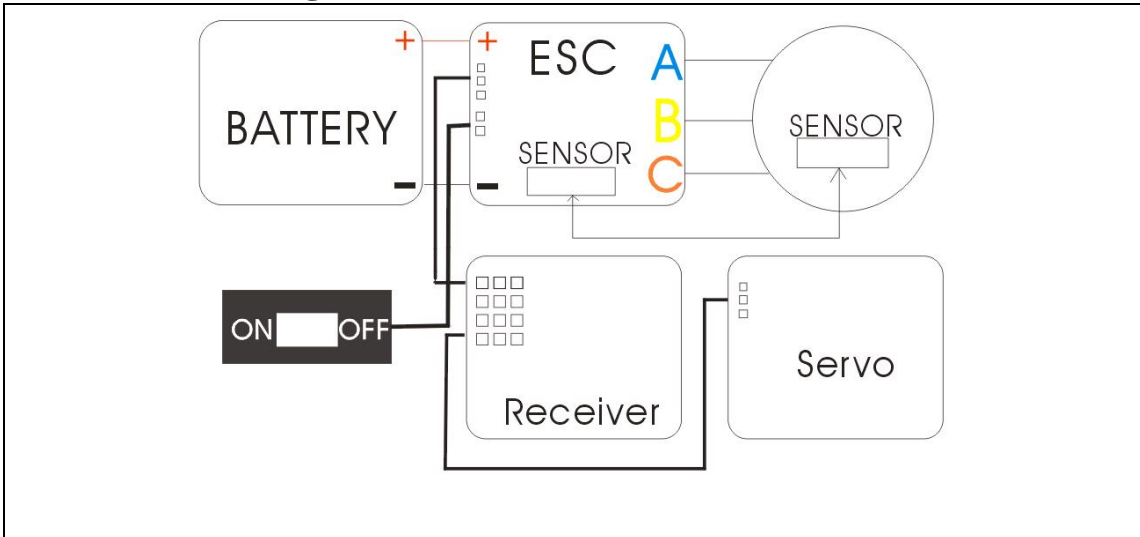

Installation Tips:

1. Connect the speed control to the receiver position channel 2.
2. Connect power wire "A" to the motor "A" solder-tabs
3. Connect power wire "B" to the motor "B" solder-tabs
4. Connect power wire "C" to motor "C" solder-tabs
5. Connect the hall sensor cable between the speed control (underneath the solder taps) and motor
6. Connect power wire "+" to battery "Plus" sign
7. Connect power wire "-" to battery "Minus" sign

Point to notes:

1. All power wires should be connected properly according to the **symbol** indicator and avoid creating solder bridges on the solder tab
2. Avoid soldering longer than 5sec per soldering joint when replacing the power wires on the speed control
3. When connecting the battery to the speed control, please make sure the battery + or – should be connected properly.

Please make sure to follow the above tips and notes to install the speed control, otherwise, the speed control may be destroyed due to the improper connection of the wires.



5. Speed Control Setup:

Step1: Transmitter Settings:

Before setup the speed control, please setup the following functions on your transmitter if available:

Functions description	Name in Radio	Setting Request
Throttle Travel	High ATV, EPA	100%
Brake Travel	Low ATV, EPA, ATL	100%
Throttle Exponential	EXP, EXPO	Set at 0
Neutral Trim	Sub Trim	Center
Servo Reverse	Throttle Reverse	Any setting, keep unchanged after the set-up procedure

If the transmitter does not have any of the above function, it is already in basic setup function.

Step 2: Set neutral, forward and brake endpoint data to the speed control:

- ⊙ Switch off the power of the speed control and please make sure the speed control is not connected to the battery.
- ⊙ Remove the motor gear to allow the wheels of the model are free to rotate.
- ⊙ Switch the transmitter on and move the transmitter throttle stick to the neutral position.
- ⊙ Connect the battery to speed control and press and hold the on/off button to turn on the unit until there is a BLUE Led light up.
- ⊙ After the BLUE Led is light up, that mean **throttle range setting** mode is entered and the neutral position has been set.
- ⊙ Move the throttle to the full throttle position, then the BLUE Led will be flashing until a solid BLUE Led will be light up. Light up BLUE Led represent the full throttle position has been set.



Step 2: cont...

- ⊙ Move the throttle stick to the full brake position, then the RED Led will be flashing until a solid RED Led will be light up. Light up RED Led represent the full brake position has been set.
- ⊙ Move the throttle stick back the neutral position again, then the flashing RED & BLUE(purple color) Led will be light up that means **throttle range setting** has been completed.
- ⊙ The speed control will be ready for use when it powers is off and on again.

Step 3: Double check the speed control function:

The speed control can be checked based on the below LED status.

Functions	Status LED Color
Neutral	BLUE
Full Throttle	RED+ BLUE
Full Brake	RED

- ⊙ If the above LED status is correct corresponding to the speed control function, then the setup procedure has been completed and it is ready for using
- ⊙ If there is a mistake during the setup procedure. Please turn off the unit and repeat the Step 2 procedure.

In setup mode, the speed control will store the neutral, forward or brake position setting inside the built-in memory and will not lose even if it is disconnected from the battery.

Notes:

If it can't enter to the "throttle range setting", please try to reverse the Throttle and brake in the transmitter setting and go to step 2 to setup the speed control again.



6. Program Card Specifications:

- * Dimension: 91mm(L) x 53(W) x 18mm(H)
- * Weight: ~68g

Program Card Operation:

Step 1: Connection with Speed control:

⊙ Switch off the speed control power and take out the speed control BEC wire from the receiver.

⊙ Connect the speed control BEC wire to the Program card connector.

Please make sure the speed control wire is connected properly based on the below description.

- Connect BEC white color wire to the program card pin at ('S') position.
- Connect BEC red color wire to the program card pin at ('+') position.
- Connect BEC black color wire to the program card pin at ('-') position.

⊙ Connect the battery to the speed control and turn on the unit. From the start, there should be a message 'Radon Series Program Card'. If any key pressed, LCD screen will show the firmware version number for around 1s and then enter to Item Setting Mode

Program Card Picture:





Step 2: How to program the mode function setting through the setting card:

- ⦿ Press the Mode key to select the mode setting
- ⦿ Press the Item key to select the mode setting values
- ⦿ Press the Update key to update each setting values of each mode
- ⦿ Press the Reset key to restore all mode setting to factory default setting
- ⦿ Press and hold the Mode and Item key together for around 2s will enter to Data Analysis mode which can be reviewed RPM, Low voltage and ESC temperature

7. LED Indicators:

- ⦿ If RED Led is flashing when the speed control is in the run, that mean the Low Voltage function is activated and reduce the power to the motor. It show the battery is lower than expected value..
- ⦿ If BLUE+RED is flashing when the speed control is in the run, that mean the Overheat Protection is activated, the speed control will cut around 50% power delivery to the motor to avoid the burning problem.
- ⦿ If BLUE LED keep blinking at neutral position, it indicates it is in Zero Timing /Blinking Mode.



8. HotWire connection with PC:

Below are the two methods to connect the speed control to the PC interface.

Method 1: Connection with the use of USB device

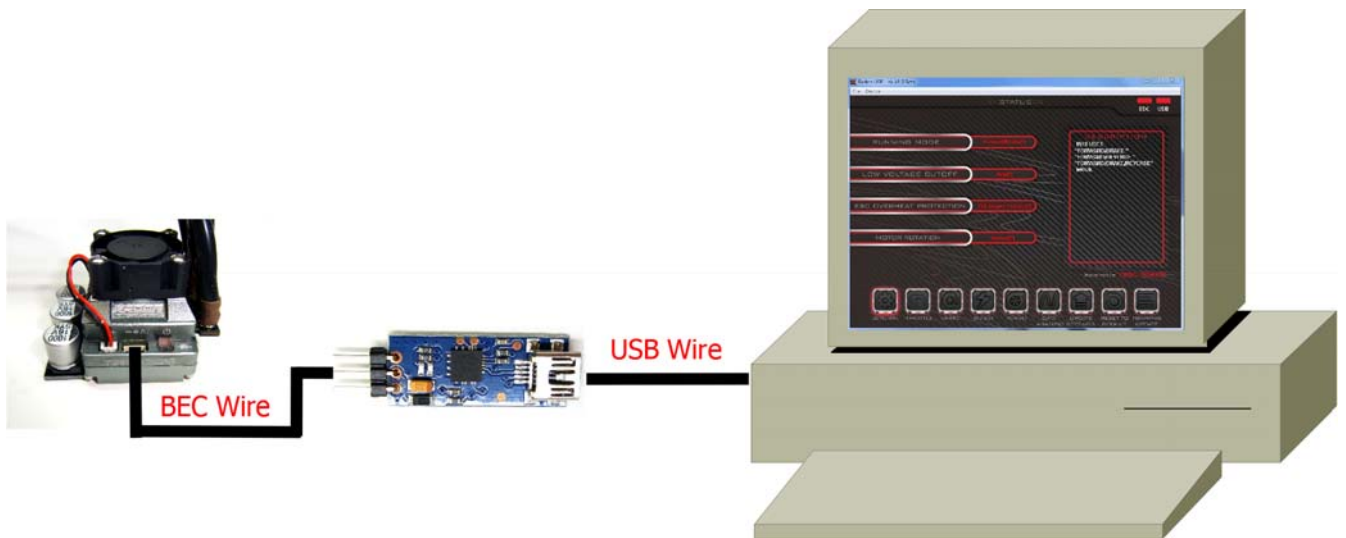

Method 2: Connection with the use of setting card

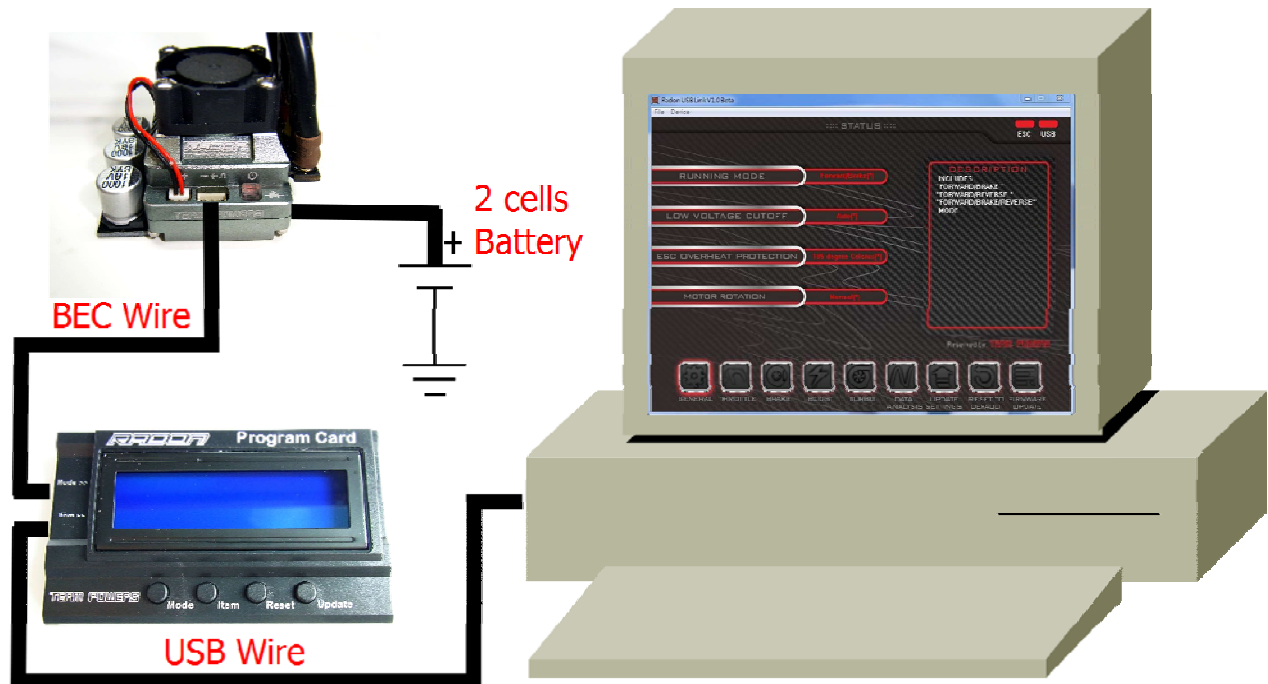



© The PC interface software can be downloaded through the website address.

[http://www.team-powers.com/radon_pg/TP_Radon_USB link V1.0.exe](http://www.team-powers.com/radon_pg/TP_Radon_USB_link_V1.0.exe)

or it can be downloaded from the www.team-powers.com home page directly.

©Support Window System: XP SP2, Windows7 and Windows8

How to program the mode function setting through PC interface:

© Install TP_Radon_USB_Link program according to the installed instruction

© Use method 1 or 2 to connect the speed control to PC through the USB wire

© Press “Radon Software” icon to open the Radon PC program interface. If the setting card or usb device is connected to PC properly, the “USB” and “ESC” icon will be lighted up. That mean all mode setting is uploaded to PC and ready for adjustment.

© If it is using the setting card to connect to PC, it needs to connect the external 2cell (7.4V) battery. After the speed control power is on, if the PC interface is connected with the speed control properly, “USB” and “ESC” icon will be lighted up. That mean all mode setting is uploaded to PC and ready for adjustment.

© After all mode setting is set, press “Update Setting” icon to update the settings

Point to Notes:

© Press “Reset to default” icon to reset all mode setting values to factory default setting

© Press “Firmware update” icon to upgrade the speed control firmware code

© About all other mode setting descriptions, it can be reviewed through the PC interface descriptions.



9. Troubleshooting Table:

<i>Symptom</i>	<i>Cause</i>	<i>Action to take</i>
No motor and servo functions	Wiring problem	Check wire and connectors
	Wrong polarity when connecting the BEC wire to the receiver	Correct the polarity when connecting the BEC wire to the receiver
	Transmitter, Receiver or Battery defective	Replace the components one by one
	Speed control defective	Send for repair
No motor function, but servo is working	Wiring problem	Check wire and connectors
	Sensor wiring defective/missing	Change other wire
	Motor defective	Change other motor
	Speed control defective	Send for repair
While accelerating, motor stutters	Sensor wiring defective	Replace the wire
	Motor or Sensor board defective	Change other motor or sensor board
	Power Capacitor failure	Replace the power capacitor
	Radio interference	Change the components location
	Speed control defective	Send for repair
Motor runs at constant slow speed and never stops	Transmitter settings changed after setup	Repeat set up procedure
	Humidity/water in speed control	Dry the speed control
Radio Interference	Transmitter batteries empty	Replace transmitter batteries
	Bad battery connection	Check wire connection
	Receiver, transmitter or servo defective	Replace the components one by one
	Receiver or antenna too close to power wires of motor and battery	Change the components location



10. Warning Notes:

- Please read the following instructions carefully before starting to use the unit. For those users that do not have experience to use it, please seek help from the professional users.
- Please make sure the voltage applied to the unit is in the operating range and the battery + and – sign should be connected properly to the power cord of the unit. If battery +, - is reversed to connect to the unit, the unit will be burnt out.
- In case there is an abnormal operation in the unit, please turn off the unit and go to section 4 to setup the speed control again.

11. 45 days Warranty Services:

All products are manufactured according to the highest quality standards. Team Powers guarantees this product to be free from defects in materials or workmanship for 45 days from the original date of purchase verified by sales receipt. This limited warranty doesn't cover incorrect installation, operations that are instructed to users, damaged by crash or any natural disaster.

This also applies the below things on:

- ⊙ Cut off the original power plug
- ⊙ Receiver wire and/or switch wire damaged
- ⊙ Mechanical damage of the case
- ⊙ Mechanical damage of electronic components/PCB
- ⊙ Humidity/Water inside the speed control
- ⊙ Soldered on the PCB (except on solder pads)
- ⊙ Connected speed-control with reversed polarity

Before you send in this product for repair, please try to eliminate all other possibilities or improper handling by checking all other components in your model and the trouble shooting guide. If the products are sent in for repair, which do operate perfectly, we have to charge a service fee according to our pricelist.

With sending in this product, the customer has to advise Team Powers if the product should be repaired in either case. If there is neither a warranty nor guarantee claim, the inspection of the product and the repairs may be charged with a fee at the customers expense according to our price list. A proof of purchase including date of purchase needs to be included. Otherwise, no warranty



can be granted. For quick repair-and return service, please add your address and detailed description of the malfunction.

If Team Powers are unable to service those defective products that are no longer exist in the market, we shall provide you with a product that has at least the same value from one of the successor series.

The specifications like weight, size and others should be seen as in this user guideline. Due to ongoing technical improvements, which are done in the interest of the product, Team Powers does not take any responsibility for the accuracy of these specs.

Distributor Service:

- ⊙Package your product with sales receipt together with the detailed description of malfunction.
- ⊙Send parcel to your national Team Powers dealer/distributor.
- ⊙Distributor repairs or exchanges the product.
- ⊙Shipment back to your usually by COD (cash on delivery), but this is subject to the general policy of your national Team Powers dealer/distributor.

If any further information need upon reviewing the instruction, please feel free to contact **enquiry@rc-explorer.com**. For more about Team Powers product information, please go to the below web sites. <http://www.rc-explorer.com> or <http://www.team-powers.com>.